

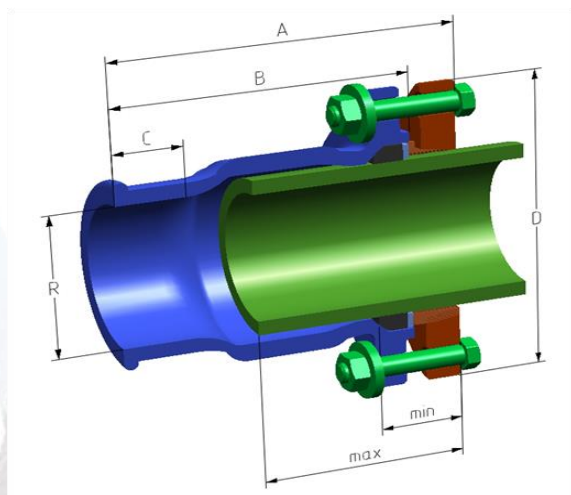

AGAflex Sp. z o.o.  
Sierakowo 108, 06-300 Przasnysz  
www.agaflex.pl  
Polub nas na Facebooku 



### Technical data card: model Flange IK



Catalog No	DN	Male thread R	~A [mm]	~B [mm]	~C [mm]	~D [mm]	min [mm]	max [mm]
10020017	65	2 1/2"	152	127	30	150	45	95
10020070	70	2 1/2"	152	127	30	150	45	95
10020018	80	3"	165	144	35	160	50	110
10020019	100	4"	175	130	37	190	55	120



System zarządzania  
ISO 9001:2015

www.tuv.com  
ID 910809711

tel. +48 29 746 33 80, +48 29 691 70 94

e-mail: [biuro@agaflex.pl](mailto:biuro@agaflex.pl)



AGAflex Sp. z o.o.  
Sierakowo 108, 06-300 Przasnysz  
www.agaflex.pl  
Polub nas na Facebooku 



### Application:

AGA fittings are used for sealing and repairs of damaged water installations (also drink water), extending water installations and building. AGA fittings are used for connecting steel and polyethylene PE pipes

### Technical features:

- working pressure : 16 bar
- maximum operating temperature 80°C
- diameters: from 2 1/2" to 4"

### Components of AGA Fittings:

- sleeve and nut: malleable iron (EN-GJMB-350-10) and ductile iron (EN-GJS-400-15) zinc coating
- compression ring: galvanized carbon steel
- washer: galvanizing carbon steel
- sealing ring: NBR rubber

**National Technical Assessment:** ITB-KOT-2020.1243 edition 1.

### Range of application:

DN	Dimensions of pipes mm		Diameter range mm	
	Steel according to PE-EN 10255	Polyethylene PE according PN-EN 12201-2	Steel	PE
65	76,1	75	74,5 ÷ 76,8	74,5 ÷ 76,8
70	-	-	67,0 ÷ 72,0	67,0 ÷ 72,0
80	88,9	-	87,5 ÷ 90,0	-
100	114,3	110	110,0 ÷ 115,3	110,0 ÷ 115,3



tel. +48 29 746 33 80, +48 29 691 70 94

e-mail: [biuro@agaflex.pl](mailto:biuro@agaflex.pl)